

# BRANDON



<https://brandonequipment.com>

20  
24

**Note:**

Check the link or the QR code to make sure that you use the latest version of this document:

<https://brandonequipment.com/factory-presentation-and-catalogue>



## Product contents

Background .....	2-3
Introduction .....	4-5
Fryer.....	6-15
Floor standing fryer .....	7-14
Counter top fryer.....	15
Filter cart.....	16
Dump station .....	17-18
Toaster .....	19-22
Vertical toaster .....	20
Batch bun toaster .....	21
Conveyor toaster .....	22
Heavy duty griddle .....	23
Marinator.....	24-25
Breading table.....	26-27
Heated display cabinet.....	28-29
Holding cabinet.....	30-32
Noodle boiler .....	33-35





---

## **BACKGROUND**

---

### **Expert in food equipment**

Established in the year of 2000, Brandon Manufacturing is a foreign direct investment from Hong Kong with production facility of over 12,000m<sup>2</sup>. We specialize in manufacturing stainless steel food service equipment, serving both the commercial and household market. Our company's strength includes gas, electrical, electronic (embedded system and IoT) and sheet metal fabrication.

As far as R & D is concerned, we have filed more than 30 patents in China; most of them are application and invention related.

### **Your choice of high quality reputation**

Brandon is already a renowned name in China's commercial food equipment market. Our products are well-known for its elegant aesthetic appearance as well as meeting robust and tough handling during application. That is why you find Brandon equipment in many KFC and McDonald's outlets around the world.

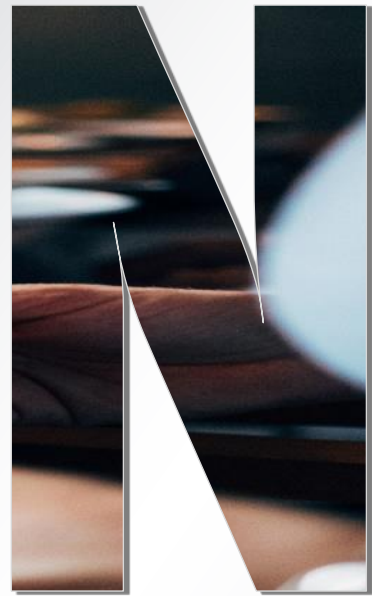

**EQUIPMENT**

## Sophisticated manufacturing system

- ISO9000, ISO14000, ISO45000
- ERP, MES, TQM and 5S
- Robotic bending
- Robotic welding (TIG, MIG and laser welding)
- Laser tube cutter
- Automatic deburring machine
- Salvagnini panel bender

## Product design competence

Well versed in safety norms around the world, including:  
CSA1.8, EN203, EN498, GB4706, AGA4563, EN60335,  
NSF...

20 years designing gas and electric equipment





# COOKING EQUIPMENT

## Quick Service Restaurant



## Cooking equipment for quick-service restaurant (QSR)

The requirements for cooking equipment in a quick-service restaurant can vary based on the specific menu, cuisine, and operational needs of the establishment. Here are some essential cooking equipment types that you might find in a QSR to facilitate efficient and fast food preparation

- Griddles: burgers, sandwiches, pancakes, breakfast foods (eggs, bacon, etc.) and sautéed vegetables.
- Fryers: French fries, chicken tenders, and other deep-fried foods. They ensure fast cooking and a crispy texture.
- Microwaves: to quickly heat or reheat certain menu items.
- Toasters (Toaster ovens or conveyor toasters): toast buns, bread, sandwiches and breakfast items.
- Charbroilers: meats (such as steaks, burgers, chicken, and seafood), vegetables, certain types of bread.
- Steamers: vegetables, rice, dumplings.
- Salamanders/Broilers: These are used to quickly melt cheese, brown the tops of dishes, or add a finishing touch to certain items.
- Ovens: baking or roasting items like pizzas, baked goods, and roasted meats.
- The specific requirements for cooking equipment can vary based on factors like the type of cuisine served, the size of the restaurant, the menu complexity, and the available space. Before setting up a quick-service restaurant, feel free to talk to us to have a better idea of what equipment is suitable for your needs.

## What are the difference of cooking equipment for quick service restaurant and hotel?

Cooking equipment for quick-service restaurants and hotels can have some similarities, but there are also key differences based on the nature of their operations, the scale of their services, and the types of food they offer.

As Brandon started out as a QSR equipment maker and eventually manufactures hotel equipment, we are in a position to make a comparison to assist users to decide what cooking equipment they should need.

	QSR	Hotel
Menu Complexity	Focused	Wide range
Production volume & scale	High	Not as high
Service Timings	Peak hour	All-day dining (ADD)
Equipment efficiency & speed	Fast	Not as fast
Equipment operating cost	Low	Not the biggest concern
Equipment versatility	Dedicated	Versatile
Equipment Presentation	Functional	Presentable
Space constraint	Space efficient	Extensive set up



A good deep fat fryer is indispensable in a kitchen.

The flavor and odor of food and marinades dissolved in fat are released into the air. The aroma of French Fries makes you salivate even before you taste it. But what kind of fryer produces crispy food for you?

## **Power and recovery time**

The power must be sufficiently large to ensure short recovery time to have crispy food. It is best illustrated with a test on the French Fries. The shorter the recovery time, the crispier the food. A general rule is that if a fryer cannot recover its temperature within 2 minutes, the French Fries is soggy.

## **Functionality and durability of computer control board**

Brandon's versatile computer control board takes the guess work out of your deli workers and keep your food quality consistent. Brandon designs and manufactures our own control board. Such vertical integration enables us to focus on quality rather than to cut corners on a resistor or inductor for a few cents, which is always at the expense of the durability and stability of the fryer. Almost without exception, our competitors outsource their computer control board and thus have no control on quality and cost.

## **Filtration**

Oil needs to be filtered to lengthen its lifespan and guarantee food quality. In view of an increasingly small kitchen in restaurants, filtration can be integrated in our fryer to keep the footprint small. The deep cleaning mode for oil in our computer control board helps you save cost in oil consumption.





Model: FRYA18CF2-11

### Accessories:

- Fryer baskets
- Crumb screen
- Drain clog clearance prod
- Drain oil extension pipe

### Features:

- Flat bar heater: low density, long life.
- Heating element can be swung up for fry pot cleaning.
- Special heater enclosure to prevent oil ingress.
- Space saving built-in oil filter. Oil receptacle can be easily accessed for filter envelop changing.
- Deep cylinder cold area (If customers want a low fuel consumption pot, please choose our FRYS flat pot series)
- High temperature safety limit.
- Stainless steel drain valve with safety interlock.
- Casters for mobility
- Computer control board

- More than 20 programmable cooking channels
- Boil Out Mode for cleaning
- Deep Cleaning mode for oil filtering
- Load compensation
- AIF (Rush hour filter reminder by pass)
- Automelt cycle for solid shortening (oil)

### ● Capacity:

32 liter for per full vat, 15.5 liter for per split vat (Cold zone series),  
23 liter for per full vat, 11 liter for per split vat (flat pot series).



Model: FRYA18CF1

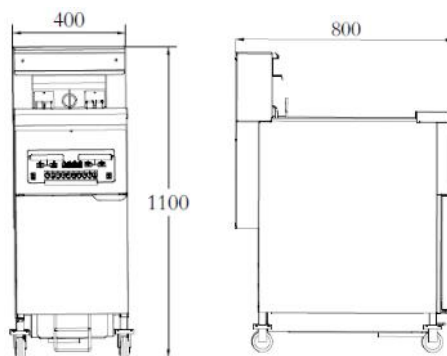





Model FRYA18CF3-211

## Model configurations

Model	Dimensions (mm)	Power	Fry Area	Number of full vat	Number of split vat	Position of Split vat
FRYA18CF1	400 x 800 x (880+220)	380 V, 50 Hz, 18 kW	350 x 405 mm	1	0	N/A
FRYA18CF1-02	400 x 800 x (880+220)	380 V, 50 Hz, 9 kW x 2	160 x 405 mm x 2	0	2	N/A
FRYA18CF2-11	800 x 800 x (880+220)	380 V, 50 Hz, 18 kW x 2	350 x 405 mm x 2	2	0	N/A
FRYA18CF2-12	800 x 800 x (880+220)	380 V, 50 Hz, 18kW + 9kW x 2	350 x 405 mm + 160 x 405 mm x 2	1	2	Right
FRYA18CF2-21	800 x 800 x (880+220)	380 V, 50 Hz, 18kW + 9kW x 2	350 x 405 mm + 160 x 405 mm x 2	1	2	Left
FRYA18CF3-111	1200 x 800 x (880+220)	380 V, 50 Hz, 18 kW x 3	350 x 405 mm x 3	3	0	N/A
FRYA18CF3-112	1200 x 800 x (880+220)	380 V, 50 Hz, 18kW x 2 + 9kW x 1	350 x 405 mm x 2 + 160 x 405 mm	2	2	Right
FRYA18CF3-211	1200 x 800 x (880+220)	380 V, 50 Hz, 18kW x 2 + 9kW x 1	350 x 405 mm x 2 + 160 x 405 mm	2	2	Left





Model: FRYA18CF2-12T

- Console lock screen
  - After programming and set up, touch pad console can be locked and control shifted to the tactile buttons such as start and pause, up and down. Fryer workers will not be distracted by the many functionalities of the console.
- Temperature conversion
  - Seamless conversion from Fahrenheit to Celsius and vice versa.
- Oil ingress prevention
  - Console has undergone repeated tests to ensure that the risk of oil ingress is kept to the minimum in the trade.
- Self clean mode

### Features:

- Manual Mode
  - Providing chefs in Michelin star restaurant with easy to use traditional knobs and buttons
- Program channels
  - Limitless number of programming channels
  - Easy to set up programming channels, thereby saving set up time and employee training time
  - Quick search of menus within seconds
  - Easy to switch from one cooking channel to another
  - Built-in cooking channels for standard recipe
- IOT ready
  - Menu addition and update over-the-air (OTA), highly recommended for QSR with many outlets where it is costly to go to every fryer to set menu.
- Fine tuning
  - Parameters such as temperature calibration and load compensation time can be easily fine-tuned.
- Menu display
  - Revolutionary large font displaying food menu being fried. Gone are the times when QSR needs to rely on small stickers to display menu.
- Languages
  - English, Simplified Chinese, Traditional Chinese, French, Spanish. New languages can be prepared in just a few days.

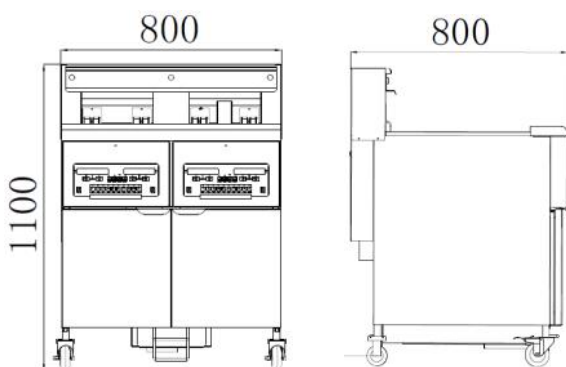

# QSR Equipment Floor standing gas fryer



Model: GF3CA

## Advantages of Autolift mechanism:

- ◇ **Consistency:** It helps maintain consistent cooking times and results for different batches of food.
- ◇ **Safety:** It reduces the risk of burns and accidents for kitchen staff as there is less need for operators to reach into hot oil.
- ◇ **Productivity:** The automation allows kitchen staff to focus on other tasks while the fryer takes care of the cooking process.

Brandon's computer control gas fryer combines two good features into one single unit. Now restaurateurs can enjoy the high power of gas cooking while at the same time utilize the automation of basket lifting mechanism and programmable cooking channels.

When frying cycle completes, the basket is automatically lifted up to ensure accurate cooking time. It is an indispensable feature when restaurant is temporarily short staffed during rush hour.

## Features:

- Automatic lifting at the end of fry cycle.
- Flame failure safety device
- Italian gas valve
- Hi temperature limiting safety feature
- High thermal efficiency (about 50%)
- Cast iron burner
- Burner tubes well positioned across the vat for easy cleaning
- Deep cold zone design reduces wasteful oil deterioration by trapping crumbs under the cooking area.
- Latch lock 1-1/4" (32 mm) ball-type drain valve: no more accidental scalding. Oil drain height: 439 mm
- Casters at the back and 6" adjustable bullet feet in the front
- High quality stainless steel construction, hygienic & easy to clean
- High grade stainless steel: SUS 304 for food contact safety
- Heavy gauge design: 1.5 mm table top and oil tank; other structural area from 1.2 mm to 2.0 mm.

# QSR Equipment Floor standing gas fryer



## Enhanced features of Computer control model

- Electronic temperature sensor: quick response to load.
- Buzzer goes off at the end of fry cycle process reaches the stage of “Shake basket reminding”. This feature is good for frying French fries.
- Precise temperature control for computer model. No unpleasant temperature overshoot which shortens oil lifespan and degrades food quality
- Current model is not suitable for solid fat (shortening) as automelt function is disabled. Please consult factory if you need it.

## IoT features of Computer control (optional)

- IoT allows user to observe the fryer status via mobile phone App, but will **NOT** be able to control it.
- 4 different status display:
  1. Fryer powering up
  2. Fryer ready to fry
  3. Cooking channel activated
  4. Cooking channel completed.
- Alerts of irregularities
  1. Abnormal gas inlet pressure
  2. Safety hi limit triggering
  3. Thermocouple disconnected
  4. Oil temperature too high

Model	No. of tank	Programming channels	Dimensions (mm)	Gas power	Capacity (L)	Fry area (mm)	Under Filter	automatical ly lifted up
GF3CA	single tank	12	393 x 885 x (910+548)	93,000 btu/h (27 kW)	23 - 25	353 x 355	No	Yes
GF3CF	single tank	12	400 x 775 x (920+251)	93,000 btu/h (27 kW)	23 - 25	353 x 355	Yes	No
GF3C	single tank	12	393 x 775 x (910+251)	93,000 btu/h (27 kW)	23 - 25	353 x 355	No	No

### Gas inlet pressure:

- Natural Gas : 2.0 kPa
- LP Gas : 2.8 kPa
- Town Gas : 1.5 kPa

Gas inlet: DN20

Electrical: 220 V, 50 Hz / 60 Hz, 100 W (for computer control & autolift), 250 W (for filter)

### Accessories:

- 2 fryer baskets
- Crumb screen
- Drain clog clearance prod
- Drain oil extension pipe

Optional: Gas regulator

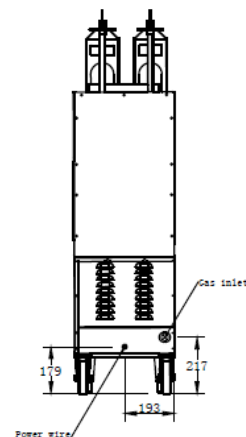
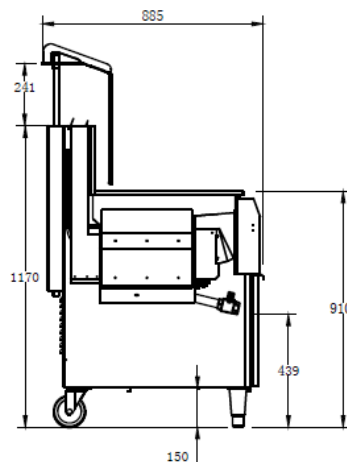
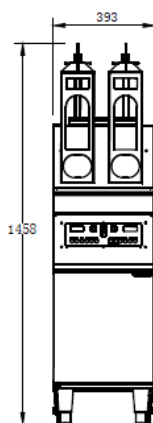

# QSR Equipment Floor standing gas fryer



Model: GFM

#### Accessories:

- 2 Fryer baskets
- Crumb screen
- Drain clog clearance prod
- Drain oil extension pipe

#### Gas inlet pressure:

- Natural Gas : 2.0 kPa
- LP Gas : 2.8 kPa
- Town Gas : 1.5 kPa

Gas inlet: 1"2 BSP Female

#### Features:

- High quality stainless steel construction, hygienic & easy to clean
- Cast iron burner
- Flame failure safety device
- Italian gas valve
- Hi temperature limiting safety feature
- High thermal efficiency (over 50%)
- Burner tubes well positioned across the vat for easy cleaning
- Deep cold zone design reduces wasteful oil deterioration by trapping crumbs under the cooking area.
- Latch lock 1" ball-type drain valve: no more accidental scalding. Oil drain height: 450 mm
- Casters at the back and 6" adjustable bullet feet in the front
- High grade stainless steel: SUS 304 (oil tank) for food contact safety
- Heavy gauge design: 1.5 mm table top and oil tank; other structural area from 1.0 mm to 2.0 mm.

Model	No. of tank	Dimensions (mm)	Gas power	Capacity	Fry area
GFM	single tank	393 x 775 x (910+251)	93,000 btu/h (27 kW)	23 - 25 L	353 x 355 mm

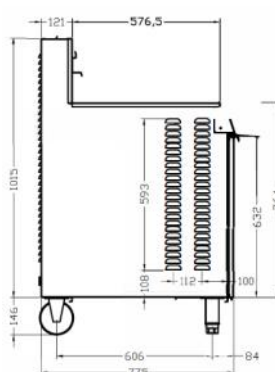

# QSR Equipment Floor standing gas fryer



Model: GF20CF

## Enhanced features of Computer control model

- Electronic temperature sensor: quick response to load.
- Buzzer goes off at the end of fry cycle process reaches the stage of “Shake basket reminding”. This feature is good for frying French fries.
- Precise temperature control for computer model. No unpleasant temperature overshoot which shortens oil lifespan and degrades food quality
- Current model is not suitable for solid fat (shortening) as automelt function is disabled. Please consult factory if you need it.

Brandon’s computer control gas fryer combines two good features into one single unit. Now restaurateurs can enjoy the high power of gas cooking while at the same time utilize programmable cooking channels.

## Features:

- Flame failure safety device
- Italian gas valve
- Hi temperature limiting safety feature
- Tube fired for high thermal efficiency (about 50%)
- Cast iron burner
- Burner tubes (heat exchanger) well positioned across the vat for easy cleaning
- Deep cold zone design reduces wasteful oil deterioration by trapping crumbs under the cooking area.
- Latch lock 1-1/4” (32 mm) ball-type drain valve: no more accidental scalding. Oil drain height: 381 mm (without filter version )
- Casters at the back and 6” adjustable bullet feet in the front.
- High quality stainless steel construction, hygienic & easy to clean.
- High grade stainless steel: SUS 304 for food contact safety
- Heavy gauge design: 1.5 mm table top and oil tank; other structural area from 1.2 mm to 2.0 mm.

# QSR Equipment Floor standing gas fryer

## Gas inlet pressure:

- Natural Gas : 2.0 kPa
- LP Gas : 2.8 kPa
- Town Gas : 1.5 kPa

**Gas inlet:** DN20

**Electrical:** 220 V, 50 Hz / 60 Hz,  
350 W (for computer control and filter)

## Accessories:

- 2 fryer baskets
- Crumb screen
- Drain clog clearance prod
- Drain oil extension pipe

**Optional:** Gas regulator

## IoT features of Computer control (optional)



- IoT allows user to observe the fryer status via mobile phone App, but will **NOT** be able to control it.
- 4 different status display:
  1. Fryer powering up
  2. Fryer ready to fry
  3. Cooking channel activated
  4. Cooking channel completed.
- Alerts of irregularities
  1. Abnormal gas inlet pressure
  2. Safety hi limit triggering
  3. Thermocouple disconnected
  4. Oil temperature too high

Model	No. of tank	Programming channels	Dimensions (mm)	Gas power	Fry area (mm)	Built-In Filtration
GF20C	single tank	12	508 x 875 x (910 + 255)	115,000 btu/h (34 kW)	472 x 463	No
GF26C	single tank	12	660 x 875 x (910 + 255)	144,000 btu/h (42 kW)	624 x 463	No
GF20CF	single tank	12	508 x 875 x (910 + 255)	115,000 btu/h (34 kW)	472 x 463	Yes
GF26CF	single tank	12	660 x 875 x (910 + 255)	144,000 btu/h (42 kW)	624 x 463	Yes

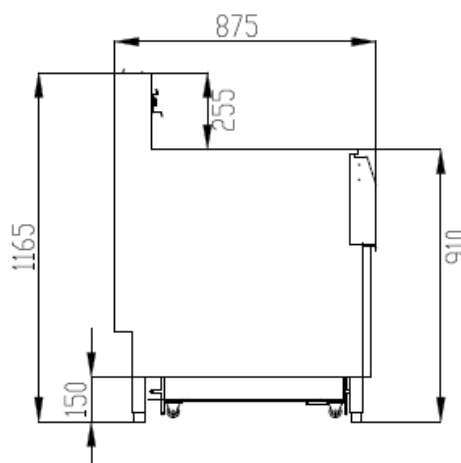
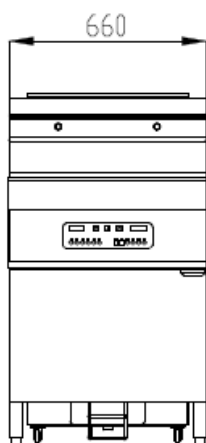



Model : CFH01C

**Accessories:**

- Fryer baskets
- Crumb screen

**Features:**

- All 304 high-quality stainless steel construction.
- Heating element can be swung up for fry pot cleaning.
- Front-facing control computer board for easy operation.
- High-quality heating tubes with longer life.
- High temperature safety limit.
- Computer control board
  - 12 programmable cooking channels
  - The temperature control is precise, with a temperature control of 1.5 degrees
  - Reminder basket function
  - Solid oil automatic oil melting function

Model	Description	Dimensions (mm)	Power	Capacity	Fry area
CFH01C	single tank	350 x 700 x (290+90)	220 V, 50 Hz, 6 kW	9L	350 x 220 mm
CFH02C	double tank	680 x 700 x (290+90)	380 V, 50 Hz, 3ph, 2 x 6 kW	9L x 2	350 x 220 mm x 2

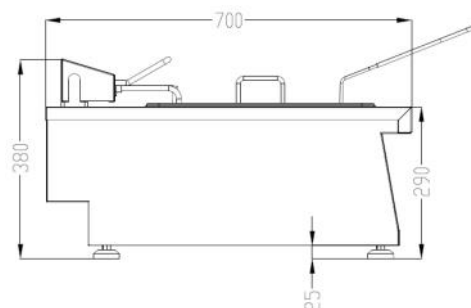
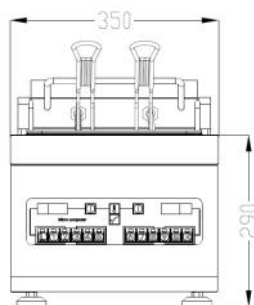





Model: F50

- Electrical: 220V, 50 Hz, 0.37KW
- Capacity: 110 lb (50 liter)
- Working height: 335 mm
- Dimension: 445(W) x 875(D) x 835(H) mm

## Features:

- Sac type suction filtering.
- Regular oil filtering extends the usable life span of your oil, thus tremendously lowers your operating cost. Filtering also removes the contaminants in oil so improves your food quality.
- Space saving model with casters.
- Oil Filter hose is imported from the America, non toxic, oil resistant and of good thermal insulation. Working pressure: 100 psi.
- The handle can be folded.
- CE compliant.

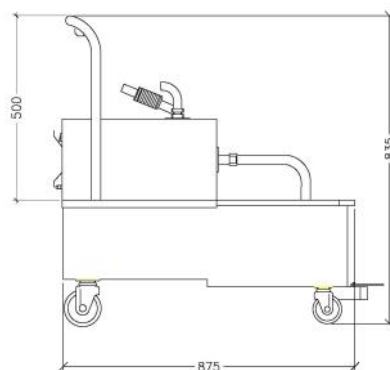
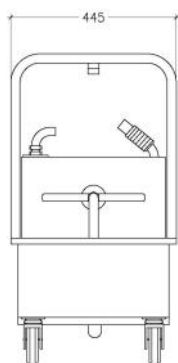



Its primary function is for deli workers to dump fried products, such as chips, potato shoestring, basket-weave and onion rings etc. Salt is added, food products are then packed into the cup with a shovel (chips scoop).

Brandon's dump station has detachable side panel so the cutout is always flexibly oriented beside the fryer.

Depending on the model, Brandon employs heat lamps or ceramic heater to maintain the temperature hot enough to keep food crispy.

Food bay is slotted to accommodate product dividers. It is handy when more than one food products need to be held at the same time such as chicken nugget, onion rings, basket weave and potato shoestring.

The back of food bay is curved and has adequate height for easy scooping. Scooping fries is essential to remove excess oil and evenly distribute salt. Holes on the bottom allows excess oil to drip down to a drip tray.





Model: DS10

Dimension: 1000 x 700 x 1560 mm

Electrical: 220 V, 50 Hz, 1.5 kW

- Heat Lamp
- Storage cabinet with swing door
- Casters for mobility (2 with locks)

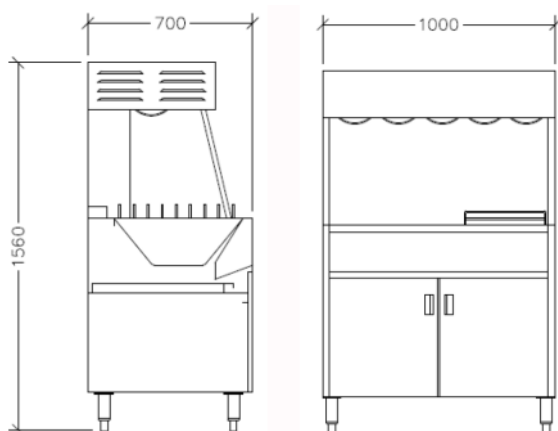

Model: DST560

Dimension: 560 x 600 x 650 mm

Electrical: 220 V, 50 Hz, 1 kW

- Quartz Heater

#### Accessories for both models:

- Rack for holding chip cup and chip bag
- Drip tray

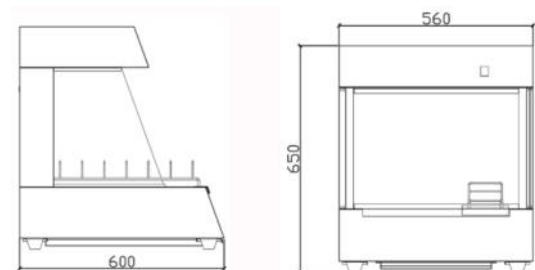

Feel free to visit our [blog post](#) to find out more about the application of this product.





Toasting refers to the process of browning or crisping food by dry heat, which brings out the natural oils and flavors in the ingredients. Toasting, when done properly, enhances the flavor, aroma, and texture of various ingredients. While we may correlate toasting to only bread, a wide range of food items, including bread, nuts, seeds, spices and grains can be toasted.

### Here are a few examples of how toasting is used in cooking:

- Bread becomes golden brown, crispy and crunchier.
- Nuts and Seeds: Nuts like almonds or walnuts when toasted enhances their nutty flavor and makes them more aromatic.
- Spices: cumin seeds, coriander seeds, or mustard seeds, when toasted, can greatly intensify their flavors and release their aromatic oils. Once toasted, the spices can be ground and used in various dishes.

### Here are a few examples of how toasting is used in cooking:

Time and temperature remain the two most important factors in a toasting process. Changing one can always affect the other. If not mastered properly, ingredients can quickly go from perfectly toasted to burnt. It is important to monitor the process closely to prevent burning and achieve the desired level of browning and flavor enhancement.

The ideal toasting temperature can vary depending on the specific ingredient you're. They may need to be adjusted based on your specific cooking equipment, the quantity of ingredients being toasted, and your desired level of toasting. Commercial toaster now comes with smart control to ensure toasting is done in an optimal way.

Brandon offers a full range of commercial toasters, **including batch bun toaster, vertical toaster and conveyor toaster**, from which you must be able to find one that meets your cooking needs.



As one of the fastest toasters in the market, Brandon's vertical toaster has a pass through time of only 19 sec, producing aromatic crunchy buns while handling sporadic in-rush of orders. In slack hours, you have the flexibility to toast smaller volume to avoid bread wastage.

Model : GT800

Dimension : 480 x 316 x 620 mm

Electrical : 220 V, 50 Hz, 2.6 kW

## Features:

- High capacity & quick toasting: pass through time 19±1s. Produce 800 pcs of bun per hour
- 6 choices of bread thickness ( optional additional thickness available, please check with factory).
- High limit (thermal cutoff)
- Chain sprocket design to ensure even toasting of each bread (bun)
- Small foot print: space saving
- Extra thermal insulation on front cover to avoid accidental scorching
- Casted aluminum platen as heat reservoir for sporadic high toasting needs with well positioned heating element to ensure even heat distribution
- Covered with Teflon paper (PTFE) to ensure non stickiness.
- Computer control: range 182 -318 C, accuracy: +/- 1.5 C
- Auxiliary heater with independent thermostat to fine-tune browning effect

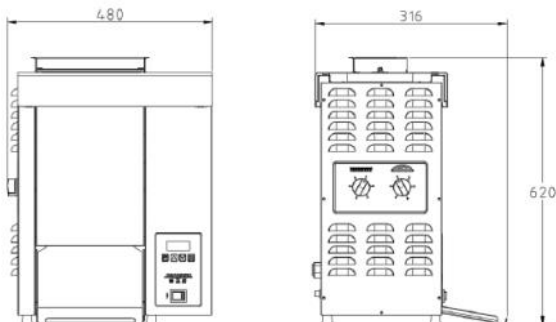

## Accessories:

- Chute
- PTFE platen cover
- Silicon belt





Model : BTN12

Dimension : 407 x 700 x 320 mm

Electrical : 220 V, 50 Hz, 2.4 kW

Batch bun toaster is classic in modern fast food environment for two reasons:

- Versatility: Batch toasters can accommodate various sizes and types of bread
- Control over individual slices: one can monitor and remove each slice of bread individually for different levels of toasting for different slices.

Brandon's revolutionary **digital batch bun toaster** gives your bun accurate and perfect caramelization, making them crunchy and aromatic.

### Features:

- Toasts up to 12 buns per batch in less than one minute
- 6 choices of bread thickness
- Timer: maximum range 60 seconds (optional 3 minute timer available)
- Buzzer reminder and LED at the end of toast cycle.
- High temperature safety limit
- 25 mm cast aluminum heating platen
- 2.4 kW power: quick heat up, 13 minutes from room temperature to 204 C (400 F)
- Uniform heating: max temperature differential across platen less than 7 C (12 F)
- Wear-resistant nickel plated surface
- Digital thermostat, sensitive to temperature change with an accuracy of +/- 1.5 C.

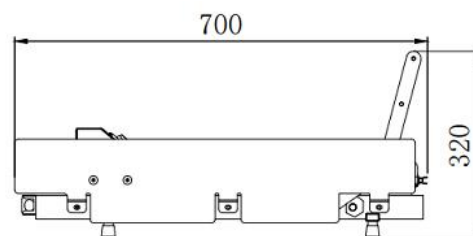
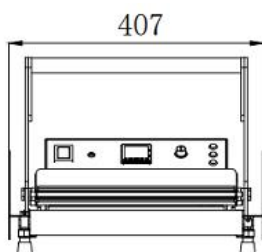

### Accessories:

- Aluminum spatula
- Stainless steel tray
- Stainless steel cover





Model : BCO16

Dimension : 1600 x 852 x 550 mm

Electrical : 380 V, 50 Hz, 6.8 kW

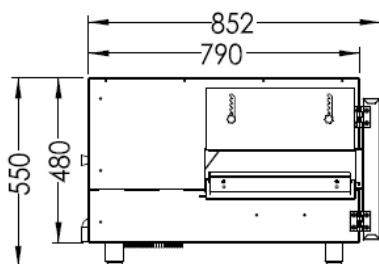
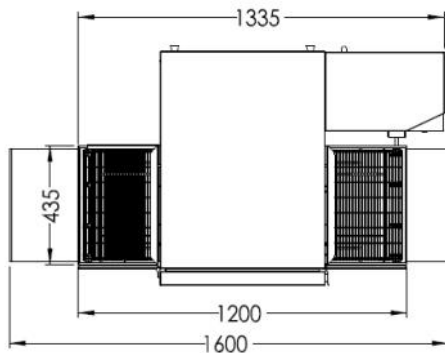

Brandon conveyor oven is versatile in its many cooking application; from bun and bread, pizza and even dessert.

As the cooking process of our conveyor oven is even and accurate, it takes the guesswork away and is a perfect choice for QSR, schools and canteen where cooking process standardization is important.

- Utilize hot air instead of heat radiation to cook food
- Convey food through cooking chamber according to preset time and ensures even cooking
- Low energy loss; more energy efficient
- Ovens can be stacked up for higher output
- Temperature range: 30 °C to 320 °C
- Touch pad control panel
- High temperature safety limit





Model : GH24

### Features:

- Frame made of high grade well polished 304 stainless steel.
- Thermostatic control up to 300 C
- Evenly distributed heat
- Large capacity (4 liter) grease drawer
- 20 mm thick griddle plate to avoid thermal deformation; also act as heat reservoir to avoid temperature plunging low during mass food preparation.
- Steel griddle plate with optional hard- chrome plating.
- High power for rapid temperature recovery.

Model	Description	Dimensions (mm)	Power
GH24	24", counter top, steel griddle plate	612 x 570 x 395	380 V, 50 Hz, 8 kW
GH36	36", counter top, steel griddle plate	916 x 570 x 395	380 V, 50 Hz, 12 kW

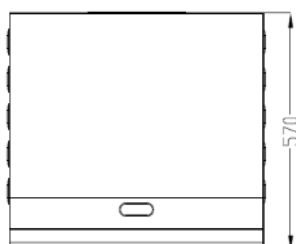
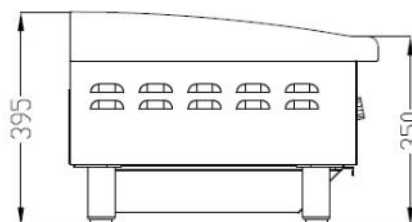
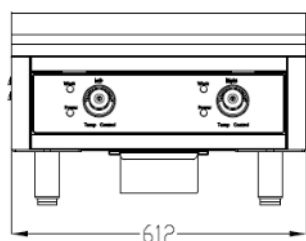





Marination is done for various purposes:

- To give food a different flavor
- To give food a sleek appearance
- To tenderize meat
- To preserve food

We are no stranger to marination; many of us have done it at home. We mix the marinade, hand rub the food, put them in a refrigerator and wait. While it is good for hobbyist, manual marination is not consistent and takes a long time. It does not meet the requirement of Quick Service Restaurant.

Commercial Marinator (or tumbler) marinates food consistently in a batch. Once you experiment and find out the relationship between marination time, batch size and marinade recipe, even your unskilled staff can produce marinated food consistently every time, every batch.

Traditional marinator is a rotating barrel and a timer. Food inside the rotating barrel rub with each other and increase marination efficiency. More advanced marinator has vacuum in the barrel, under which the food tissue is pulled apart and marinade can penetrate to fill the void. Alternate rotational direction further enhances meat massaging.

### **Value of the marinator**

- Improve food quality and consistency.
- Speed up marination to meet rush hour demand.
- Reduce labor cost and improve deli worker morale.
- Makes work flow within kitchen more standardized and scientific.





Model: BVC1

Dimensions: 907 x 466 mm

Operating Height: 958 mm

Electrical: 220V, 50 Hz, 200W

Barrel Capacity: 40 liter

Marination capacity per batch: 30 kg

#### Features:

- Fully welded barrel with leak proof gasket
- Computer control
- Alternate rotational direction
- Adjustable cycle time for each direction
- Buzzer alarms before rotation starts and after marination ends
- Barrel pressure: Minimum 0.04 MPa
- 4" casters for mobility, 2 with locks

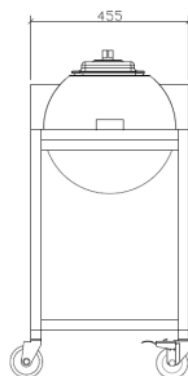
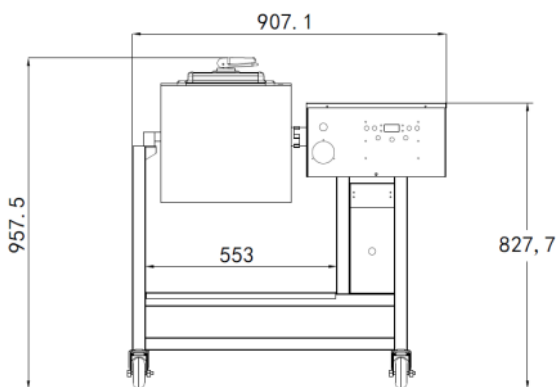
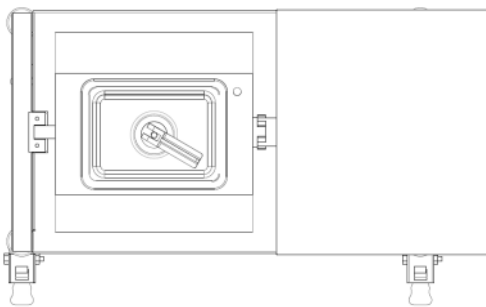

#### Accessories:

- 2 units of plastic food pans





Electric breading table is also called **batter table** or **automatic sifter**. It helps you recycle good dry breading and reduce operating cost. The improved food quality keeps your customers coming back again.

Breading is a process by which you coat the breading onto the food to impart the taste and crispy texture into the food products. Breading improves tremendously the taste of fried food.

In manual breading, breading powder is never reused or cannot be effectively recycled.

Manually sifting powder and separating fine breading from wet dough balls is a time consuming and inefficient chore. There are three steps in the breading process:

1. Put your food products into the breading pan with seasoned breading.
2. Transfer your food products with the soak basket into the pan with wet batter mix.
3. Transfer your food products into the breading pan for a second coat.

To understand the detailed procedure of breading process, please visit the blog of our website.

There are two major types of sifting technology; the vibration type and the brush- scroll type. Both types have their merits. The automatic sifting process separates your valuable seasoned breading from the wet dough clumps. Automatic sifting often takes less than a couple of minutes to complete.

### **Value of the electric breading table**

- It pays for itself by reducing breading usage. Compared with manual sifting, an electric breading table can save from 25 to 50% of your breading usage.
- An automatic sifter helps reduce labor cost and improve deli worker morale. It makes the breading process much easier for them.
- It improves your food product quality in terms of taste and appearance, and you will find your customers keep coming back.





Model : BDH1

Dimensions : 1260 x 500 x 1158 mm

Operating Height : 885mm

Sifting method : vibration

Electrical : 220V, 50 Hz, 250W

### Features:

- Stainless steel construction
- 3 mm thick food grade plastic breading pan - sturdy but light weight for easy operation
- Patented design of motor compartment to prevent breading mist ingress for hygiene and electrical safety
- Hanger for disposable hand glove.
- 3" casters for mobility, 2 with locks
- Durable on/off switch

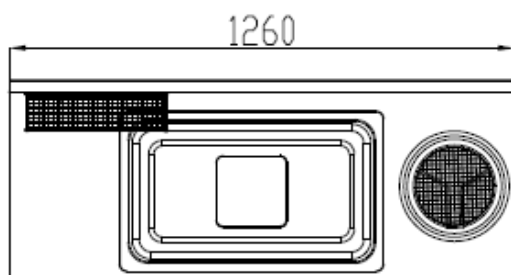
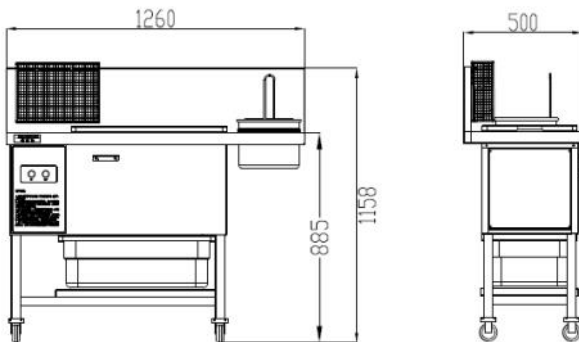

### Accessories:

- 2 breading pan
- One batter mix pan
- One soak basket and shake basket





In a nutshell, the essential functions of a heated display cabinet is to display food to trigger the buying impulse of consumers, and at the same time fulfills its food holding requirement.

### **The construction of a heated display cabinet**

The display cabinet is designed to allow for easy food loading and retrieval, so door locks are generally absent. The door of Brandon heated display cabinet is made of transparent polycarbonate (PC) to ensure food is attractively displayed. Compared with acrylic, PC has a much longer lifespan and is not easily deformed under a heated environment. Pass-through door design can be flipped up on both sides to showcase your food as well as for quick food replenishment.

### **Dry and humidified heat**

The upper tier comes with dry heat for crispy food and the humidified lower tier is good for holding fresh humid food. Humidity is maintained by a heated reservoir with water level control. Temperatures of each tier is controlled independently.

Feel free to visit [our blog](#) to find out the difference between a heated display cabinet and a holding cabinet.





Model: BW15

### Accessories:

- Tong holder
- Baking sheet pan: 660 x 460 mm

Model	Width (mm)	Number of sheet pans	Power (kW,220V)
BW11	1100	3	3.6
BW15	1520	5	4.2

### Features:

- Highly efficient heating element, adjustable food storage temperature ( 75 C ), effectively prevent bacterial breeding, up to the international food safety temperature ( 63 C+).
- Independent temperature control for upper and lower tier.
- Dry and humidified heat to keep different food types.
- Electronic water level control with low water level signal.
- Transparent durable polycarbonate swing doors for food visibility.
- Height: 840 mm; Depth: 750 mm
- High grade well polished 304 stainless steel.

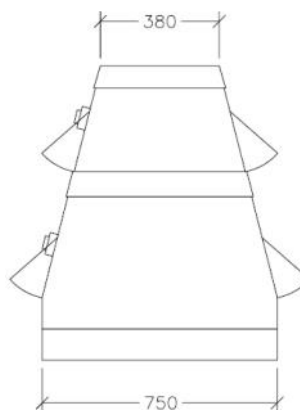
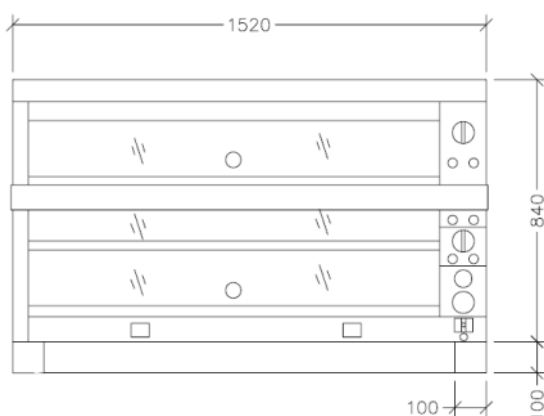

# Banquet cart

# Holding cabinet

In fast food restaurants, food is cooked ahead of rush hour and held in holding cabinets. To meet with HACCP hygiene requirement, the holding temperature needs to be at least 63C to prohibit growth of diseases and pathogen. Brandon's holding cabinets features air circulation systems to distribute warm air evenly throughout the cabinet, preventing hot spots and ensuring that all food items are kept at the same temperature. Our holding cabinet regulates the moisture level inside, which is crucial for keeping certain foods, like bread or roasted meats, from drying out while they're being held.

To help you understand more about preserving food for better quality, please feel free to read our [blog post](#).



Model: BWSC30-4

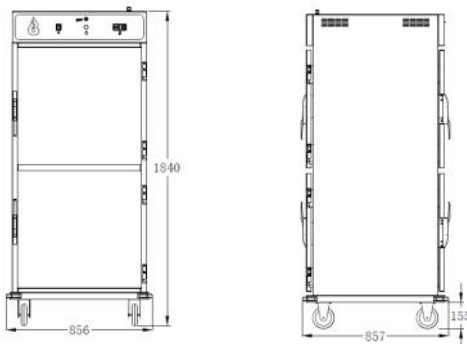

Dimension: 856 x 857 x 1840 mm

Electrical: 220 V, 50 Hz, 2.4 kW

Water capacity: 4 liter

## Features:

- Digital display electronic control panel.
- Circulating hot air to ensure thermal balance.
- Adjustable holding temperature (30 to 99C), prohibiting bacteria and pathogen growth. (HACCP requires that hot food holding temperature is at least 63C).
- Double blower design, easy to disassemble; convenient for daily maintenance.
- Stainless steel construction for easy cleaning and durability.
- Stainless steel door (with optional glass door).
- Four 5" casters (two with locks).

## Optional Accessories:

- Sheet Pan: 30 pcs 600 x 400 x 20 mm
- GN Pan: 30 pcs 1/1 x 65 mm
- Wire Rack: 30 pcs 660 x 600 mm





BWSC7-2B

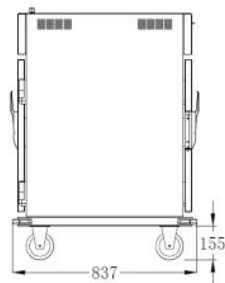
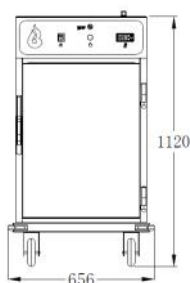

### Half Size

- Dimension : 656 x 837 x 1120 mm
- Electrical : 220 V, 50 Hz, 2.4 kW
- Temperature : up to 99 C
- Water Capacity : 4 liter
- Tier : 7

### Optional accessories

- Pans : baking pan (600 x 400) or GN 1/1 x 65 mm
- Wire rack : 415 x 640 mm

Model	BWSC7-2	BWSC7-1	BWSC7-2B	BWSC7-1B
Doors	Two	Single	Two	Single
Glass Door	N/A	N/A	Front & Rear	Front
S/S Door	Front & Rear	Front	N/A	N/A



BWSC15-4B

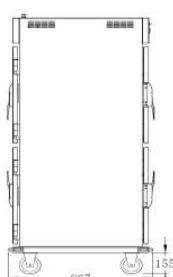
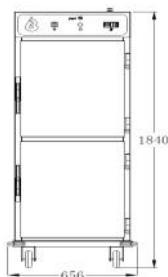

### Full Size

- Dimension : 656 x 837 x 1840 mm
- Electrical : 220 V, 50 Hz, 2.4 kW
- Temperature : up to 99 C
- Water Capacity : 4 liter
- Tier : 15

### Optional accessories

- Pans : baking pan (600 x 400) or GN 1/1 x 65 mm
- Wire rack : 415 x 640 mm

Model	BWSC15-4	BWSC15-2	BWSC15-4B	BWSC15-2B
Doors	Four	Two	Four	Two
Glass Door	N/A	N/A	Front & Rear	Front
S/S Door	Front & Rear	Front	N/A	N/A





# Banquet cart

# Holding cabinet



Model: BWP12

### Accessories:

12 pcs Sheet Pan (600 x 400 x 20 mm)

### Features:

- Simple and convenient control panel
- Circulating hot air return make temperature balance quickly.
- Accurate temperature control
- Easy for part unloading and convenient for daily maintenance
- Proofer function
- Stainless steel construction for easy cleaning and long life.
- Stainless steel door, lift-off doors stay open past 90 degrees
- Large stainless steel water pan.
- 12 pcs sheet pan
- 4 casters 5 inches (127 mm), 2 locking.

Model	Dimensions (mm)	Power	Temperature	Humidity
BWP12	623 x 894 x 1737 mm	220 V, 50 Hz, 2.1 kW	30 - 80 °C	2.5

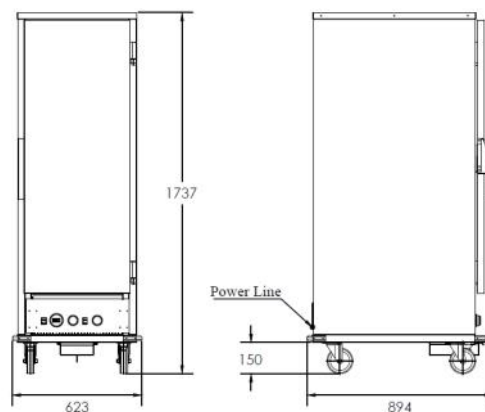



Model: NGC6

### Control panel features

- Work with auto-lift system
- 2 programming channels per basket, 12 programming channels altogether.
- Adjustable stand-by water temperature to reduce energy loss.
- Display water temperature while cooking.

### Accessories:

- Six noodle basket

Noodle Boiler, or Ramen boiler as it is called in Japan, is widely used in conventional Asian noodle shop. People from different countries have a diversified preference on noodle hardness, which is largely dependent on the cooking time accuracy. As such, the digital control semi-automatic noodle boiler plays a pivotal part in guaranteeing your noodle quality.

### High power

- 13 kW (44,500 btu/h) each tank x 2 , preheat water from 20 deg C to boiling state in less than 15 minutes.
- Recover temperature in peak hours in no time.
- Depending on the noodle type and hardness requirement, it takes as little as one minute to boil noodle, making total capacity 270 servings per hour

### Features:

- Manual water inlet in the back
- Electronic ignition
- Flame failure supervisory device for safety
- Fresh water replenished by faucet in the back while old water flows into overflow.
- Dry boil protection
- Thermal efficiency 79%. Save you energy cost!
- Capacity: 30L each tank x 2

Model	Dimensions (mm)	Power	Gas inlet / Water inlet	Drain outlet
NGC6	650 x 800 x 800 +50	Gas : 44,500 btu (13 kW) x 2 Electric : 220V,50Hz,10W	DN15	DN40



## Highly productive

Brandon noodle boiler preheats to boiling point in less than 15 minutes.

The following data was taken at ambient temperature of 19 C. Actual warmer kitchen temperature will shorten preheat and recovery time even further

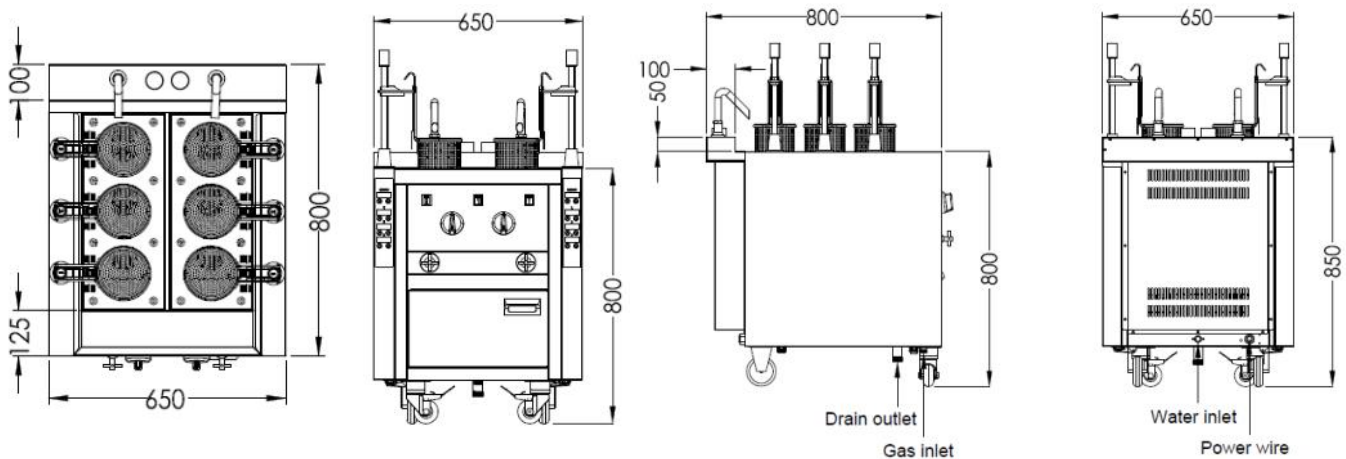
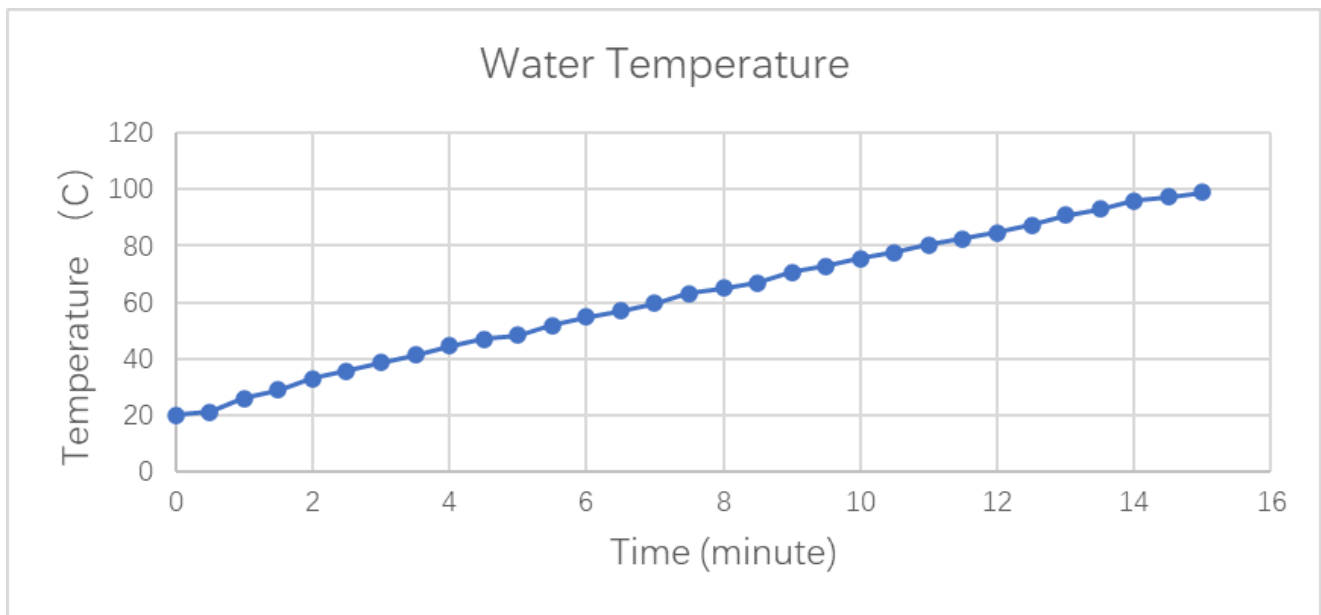



Model: NEC6

Size: 600 x 800 x 800 + 100 mm

Power: 380V,50Hz,12kW

Water inlet: DN15

Drain outlet: DN40

### Accessories:

- Six noodle basket

### Features:

- Manual water inlet in the back
- Equipped with water shortage protection float device
- Fresh water replenished by faucet in the back while old water flows into overflow.
- Motor-driven chain drive mode, ultra-quiet design
- Dry boil protection
- Power: 6kW each tank x 2
- Recover temperature in peak hours in no time.

### Control panel features

- Work with auto-lift system
- 2 programming channels per basket, 12 programming channels altogether.
- Adjustable stand-by water temperature to reduce energy loss.
- Display water temperature while cooking.

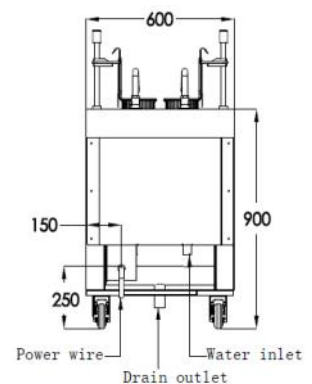
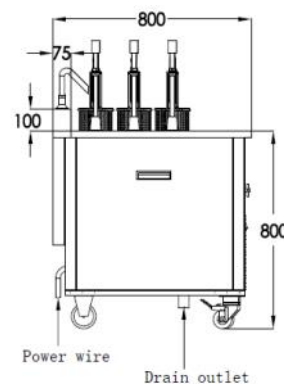
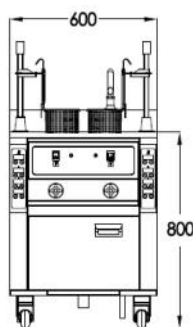
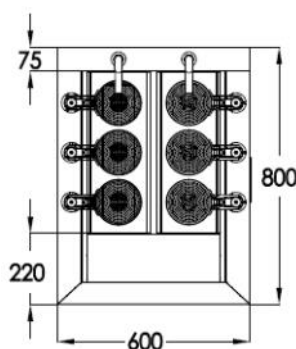



Website

Guangzhou Brandon Equipment Manufacturing Co, Ltd

Website: <https://brandonequipment.com>

Product Application: <https://brandonequipment.com/blog>  
(professional cooking)

Catalog version 240429

BRANDON